

# AT/AP

Automatic overwrapper with heat-sealable material with belt(AT) or plate(AP) sealing

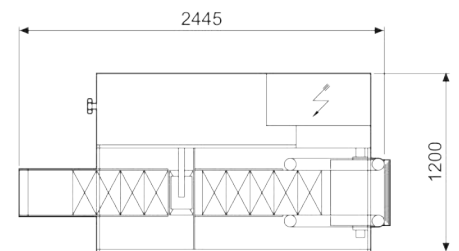

Mechanical speed per minute	<b>STROKES / 1'</b>	50+60
Motors	<b>KW</b>	1
Power Absorption (max.)	<b>KW</b>	4,3
Air Consumption	<b>NI/1'</b>	300
Air pressure	<b>bar</b>	5/6
Gross Weight	<b>Kg.</b>	~1350
Net Weight	<b>Kg.</b>	~1000

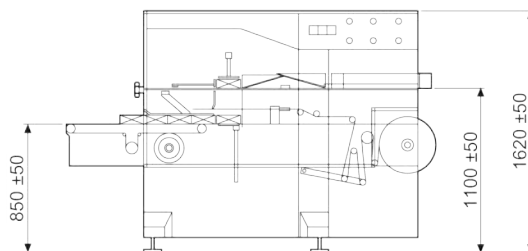
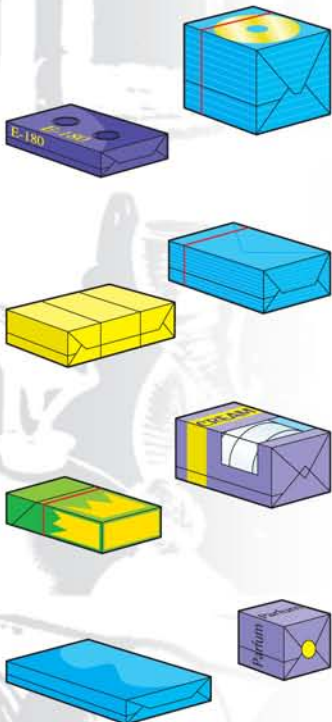
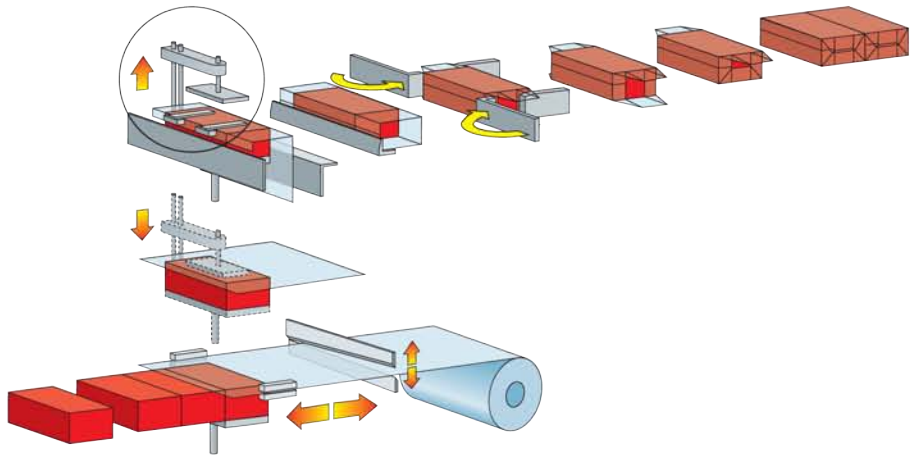
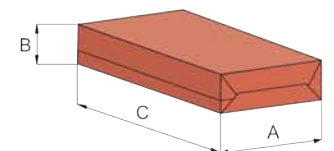
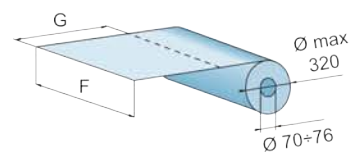

		<b>A</b>	<b>B</b>	<b>C</b>	<b>F</b>	<b>G</b>
Size range	min.	35	15	60	100	150
	max.	150	80	300	400	500

The above technical data is not binding and may be subject to change without prior notice.





## **CAMPAK France**

**81, rue Pasteur  
77462 St-Thibault des Vignes  
Tel:01 60 31 54 68  
Fax: 01 60 31 54 69  
e-mail: [campak@campak.fr](mailto:campak@campak.fr)**

**<http://www.campak.fr>**



**Machines  
Catalogue**